

REV	DATE	DESCRIPTION	DRAWN

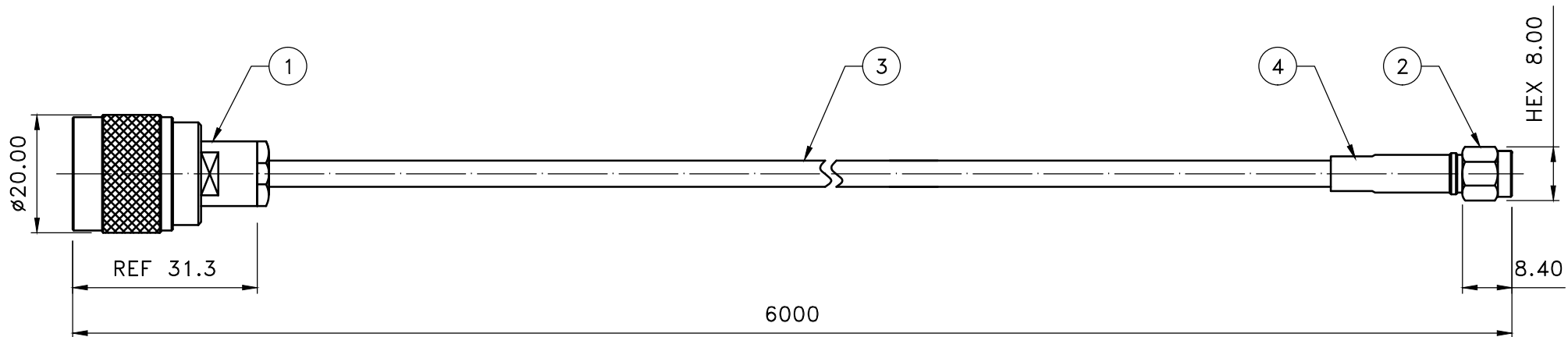

NOTE:

- 1.N MALE CLAMP**
CENTER PIN GOLD PLATING 3μ THICK OVER NICKEL STRIKE
BODY NICKEL PLATING 70μ THICK OVER NICKEL STRIKE
BRASS AND PTFE PER SGS
FINISH PLATING THICKNESS IN MICRO-INCHES
COPPER PARTS AUTOMATIC CNC MANUFACTURING
- 2.SMA MALE CRIMP**
BRASS PER JIS-C3604
PTFE PER ASTM D1457 AMD ASTM D1710
FINISH PLATING THICKNESS IN MICRO-INCHES
COPPER PARTS AUTOMATIC CNC MANUFACTURING
- 3.LOW LOSS 200 COAXIAL CABLE/3D**
ATTENUATION : 0.32dB/m@900MHZ 0.42dB/m@1800MHZ 0.61dB/m@3000MHZ
CONDUCTOR : BARE COPPER WIRE/ \varnothing 1.12mm
INSULATION : GAS-FPE/ \varnothing 2.95mm
TAPE : BONDED ALUMINUM FOIL
SHIELD : TINNED COPPER WARE/16*4*0.10mm/59% COVERAGE
JACKET : PVC/ \varnothing 4.95mm

Prohibit re-circulating



NO	DESCRIPTION	MATERIAL	FINISH	Q'ty
4	D0176 (SHRINK TUBE)	PE	BLACK	1
3	LLC200	ASSY	BLACK	1
2	SMA-1001-41-F2-TGG	BRASS	GOLD	1
1	N-1109-15-F-TGN	BRASS	NICKEL	1

NOTE	DIMENSION	TITLE
1. STRIP ALL BURRS. 2. ALL DIMENSIONS ARE AFTER PLATING. 3. DIAMETERS ON COMMON CENTERS. 4. CHAMFER 1ST & LAST THREADS 45°. 5. BREAK ALL CONNERS & EDGES CO.15 MAX.	UNLESS OTHERWISE NOTED TOLERANCES 0.X=±0.2 0.XX=±0.1 CABLE LENGTH: $L \geq 10000 = +50$ $1000 \leq L < 10000 = +30$ $L < 1000 = +8$	1109-SMA1001
		DRAWING NO. 110915200100141-A6000
		APPROVED
		DRAWN DATE 05/26/21
		CHECKED
		SCALE 1:1
		DRAWN JASON
		UNIT mm

All creative content and details belonging to HYT's confidential, and the owner, without consent, Do not posted, theft, copied and sent to a third party.